



## GELNORM®-Geltimer GT-SP – SLIM LINE



The GT-SP Slim Line Geltimer with integrated control and time measuring equipment is the compact successor model of the Geltimer TC.

The new Gel Timer is mechanically, and from the point of view of the measuring technology, identical with the standardised Gelnorm® Geltimer model of which 1000 are in operation.

The compact design, the LCD lighting for the background and the blinking green button with the coloured running light in the test stamper spiral, make up a simple and conveniently arranged solution.

The voltage used is 24 VAC 50 / 60 Hz obtained via a safety transformer.

The GELNORM®- Geltimer is intended for the measurement of Gelation time of reaction resins in accordance with DIN 16 945 Page 1, DIN 16 919 and DIN EN ISO 9396.

The instrument incorporates a switch-off mechanism that responds to pressure: the gelation time limit is reached when the measuring stamper meets a defined reaction force in the reaction resin. As a result of this automatic switch-off system, the size of resin sample employed is not limited. The disposable stamper of stainless steel wire carries out a defined reciprocating movement as soon as the instrument is set in operation and, when the change in viscosity is reached, a built in timer is stopped and the gelation time can be read off.

- unsat. Polyester resins
- Epoxid resins
- Polyurethane resins
- Acrylic resins
- Silicone resins
- Phenolic resins





## Description of the Instrument

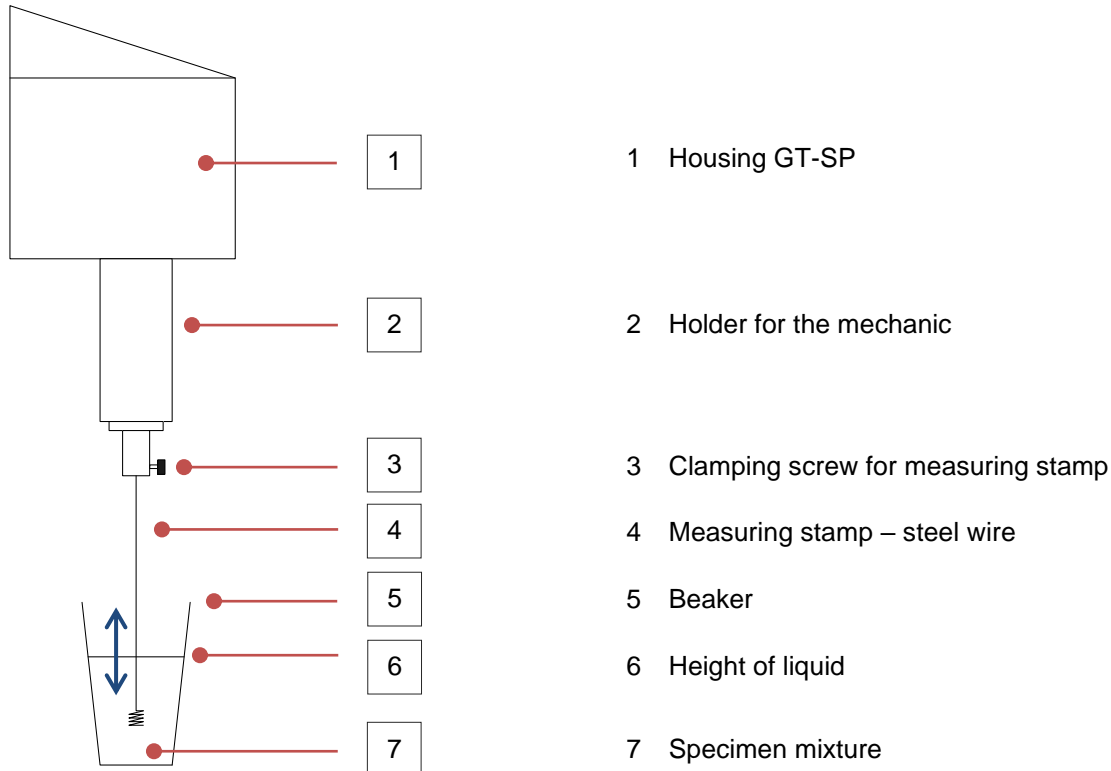

## Time measurement and the reciprocating cycle

The control unit GT-SP employs a time measuring instrument illuminated from the rear using an LCD system and a start button with optical indicator. Time measurements up to 99 hours 59 minutes 59 seconds can be conducted.

The reciprocating movement of the measuring stamper is set to 10 seconds on the standard unit. On request other reciprocating cycles and movements can be provided.

Tripod with support rod for GT-SP, Dimensions (mm)

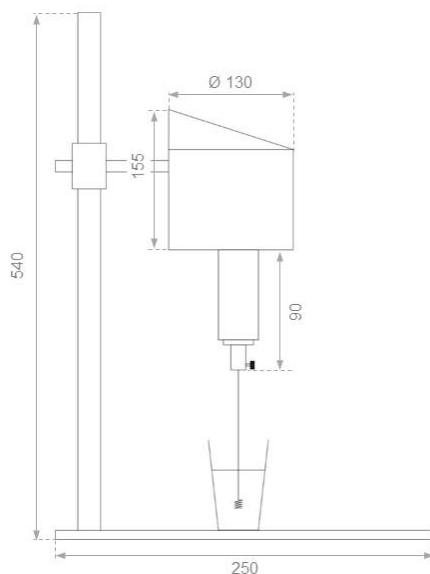



## Preparation

Install the stamper on Geltimer

Connect the power supply

Check, if Timer setting is on 00:00:00

Place 100g reaction resin (deviations of 1% are permissible according to DIN 16 945) in a beaker. Add hardening agent and, if applicable, accelerator of the required quantities as specified by the supplier, measuring to an accuracy of 0,01g After adding of hardening agent stir test mixture (approx. 1 minute).

Set measuring cup under the stamper. Let down the test unit with the stand and adjust the stamper (stamper should be approx. 50% in the specimen mixture)

The blinking light shows in the ring around the START button. Press START button. The start button lights up green and the measuring time is in process.

When the gel point is reached, the electronics switch off the motor, the green start button flashes and the LCD displays the gel time.

The switch-off mechanism is based on a defined upwards force, which acts on the measuring stamper. This switch-off mechanism is fixed. A control or calibration can be done with a balance.

The stampers are disposed of when the measurement has been completed. These parts are not cleaned for re-use.

## Technical Data

### Geltimer GT-SP

Time measurement	0 ... 99h 59min 59s
Accuracy	± 1 second / 2 hours
Reciprocating cycle	10 secs., on request other reciprocating cycle times can be offered
Dimensions	test unit:            ∅ 130 mm stand:                plate 250 x 200 mm / height 540 mm
Total weight	~ 5,0 kg (GT-SP with Stand)
Housing material	eloxed aluminium
Operating voltage	24 VAC
Power used	5 VA
Operating temperature	0 °C ... 50 °C
Storage temperature	-30 °C ... 50 °C
Relative humidity	< 85 %, not condensing
Place of use	only indoors
Height, up to max.	2000 m
Degree of dirt contamination	2
Supply voltage variations	+/- 10 %
Access voltage category	category II



## Ordering code, Article number

Gelnorm® Geltimer GT-SP 100.50  
incl. stand and power supply 230 VAC / 24 VAC

A power supply unit with 115VAC supply is also possible on request

## Spares material

Stampers – steel wire, package of 500 pcs. 20.35  
Length = 150 mm

Power Supply 230 VAC / 24 VAC 100.90